



**KMS 4**  
MOUNTING-ADJUSTMENT

# KMS 4 MOUNTING ADJUSTMENT

## Description

The KMS-4 is a universally applicable hydraulic pressure measuring system for the precise adjustment and detection of the preload between cutting or magnetic and anvil cylinders for rotary cutting units. The currently set cutting pressure is exactly indicated on the manometer in bar.

The KMS-4 is usually installed by using the Klemmfix quick-release unit (optional). The use of the Klemmfix significantly simplifies the installation, eliminating laborious screwing in of the threaded spindle. Klemmfix is mounted on the pressure bridge with 2 fixing screws. For some cutting units the existing hole of the standard threaded spindle must be drilled out. (16 to 17 mm or 20 to 21 mm)

Please observe the drilling dimensions for the fixing holes of the Klemmfix.

## Adjustment

By turning the star handle the preload can be set in the system, and indicated on the manometer.

## Important NOTE!

Do not adjust the pressure beyond the display area, as the manometer will be damaged.  
Do not turn the spindle on the manometer to build up pressure.



QUALITY BUILT + SERVICE DRIVEN

# ASSEMBLY INSTRUCTIONS

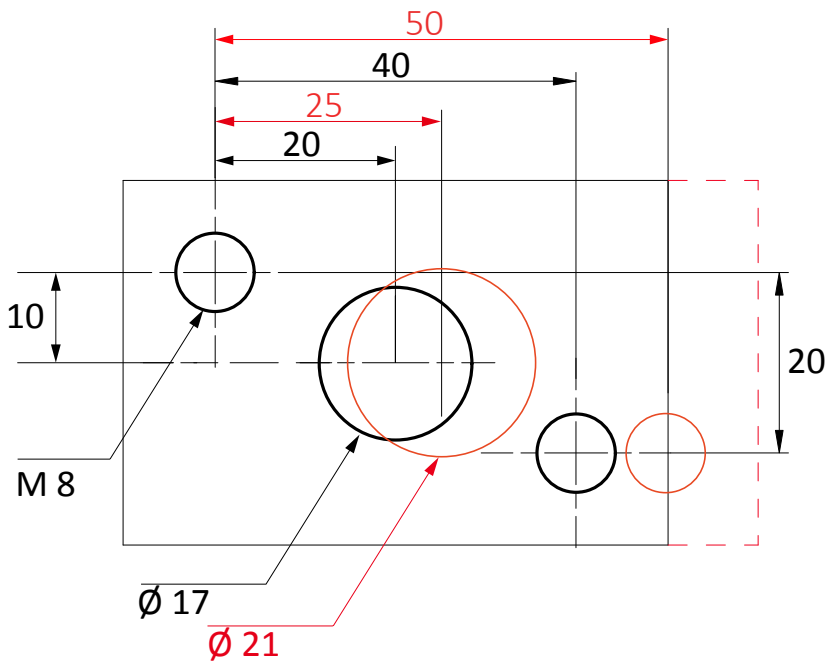

Dimensions in red with spindle diameter 20 mm  
Dimensions in black with spindle diameter 16 mm

The KMS-2 can either be screwed directly into the spindle bridge or fixed to the spindle bridge with the optionally available Klemmfix.

**Prerequisite:** Drill mounting holes and cut thread M8.

## Working steps

1. Fix the Klemmfix with the enclosed 2 screws M8x35 (M8x40).
2. Pull the locking pin.
3. Press slide.
4. Insert threaded spindle up to pressure bridge. Push the slide back again.  
⇒ Locking pin snaps in.
5. Set the cutting pressure using the star grip and read off the manometer.

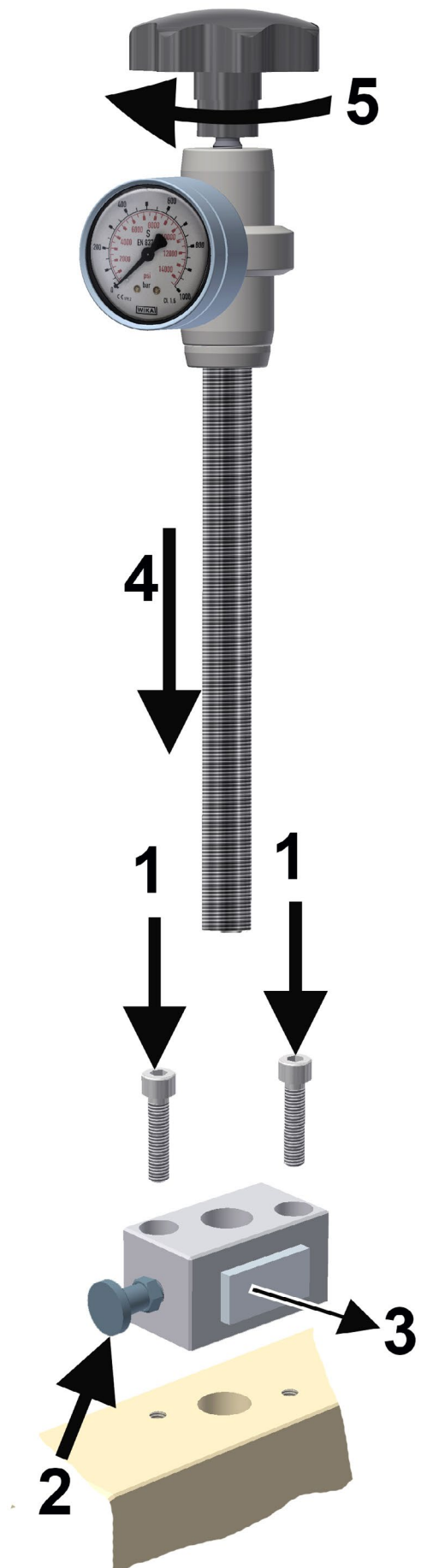



### **Team Germany**

**Kocher+Beck GmbH + Co.  
Rotationsstanztechnik KG**



Dieselstraße 6  
72124 Pliezhausen



+49 (0) 7127 / 9785 – 0



info@kocher-beck.de



www.kocher-beck.com



### **Team USA**

**Kocher+Beck USA L.P**



15850 West 99th Street  
Lenexa,  
KS 66219



+1 (913) 529 – 4336



info@kocher-beck.com



www.kocher-beck.com



### **Team United Kingdom**

**Kocher+Beck UK LTD**



Brunel Way,  
Stephenson Industrial Estate  
Coalville, Leicestershire,  
LE67 3HF



+44 (0)1530 812400



sales@kocher-beck.co.uk



www.kocher-beck.com



### **Team Russia**

**OOO Kocher+Beck**



142116 Russian Federation  
Moscow dist.,  
Podolsk,  
Domodedov ave. 47



+7 (495) 660 02 28



verkauf@kocher-beck.ru



www.kocher-beck.com

