



KMS 2
MOUNTING-ADJUSTMENT

KMS 2 MOUNTING ADJUSTMENT

Description

The KMS-2 is a universally applicable hydraulic pressure measuring system for the precise adjustment and detection of the preload between cutting or magnetic and anvil cylinders for rotary cutting units. The currently set cutting pressure is exactly indicated on the manometer in kilonewton and bar. (2 versions: 100/160 bar)

The KMS-2 is usually installed by using the Klemmfix quick-release unit (optional). The use of the Klemmfix significantly simplifies the installation, eliminating laborious screwing in of the threaded spindle. Klemmfix is mounted on the pressure bridge with 2 fixing screws. For some cutting units the existing hole of the standard threaded spindle must be drilled out. (16 to 17 mm or 20 to 21 mm)

Please observe the drilling dimensions for the fixing holes of the Klemmfix.

Adjustment

By turning the star handle the preload can be set in the system, and indicated on the manometer. To start the machine, a force of about 4 kN, which corresponds to the KMS-2 with a pressure of about 40 bar, is usually sufficient.

Important NOTE!

Do not adjust the pressure beyond the display area, as the manometer will be damaged.
Do not turn the spindle on the manometer to build up pressure..



ASSEMBLY INSTRUCTIONS

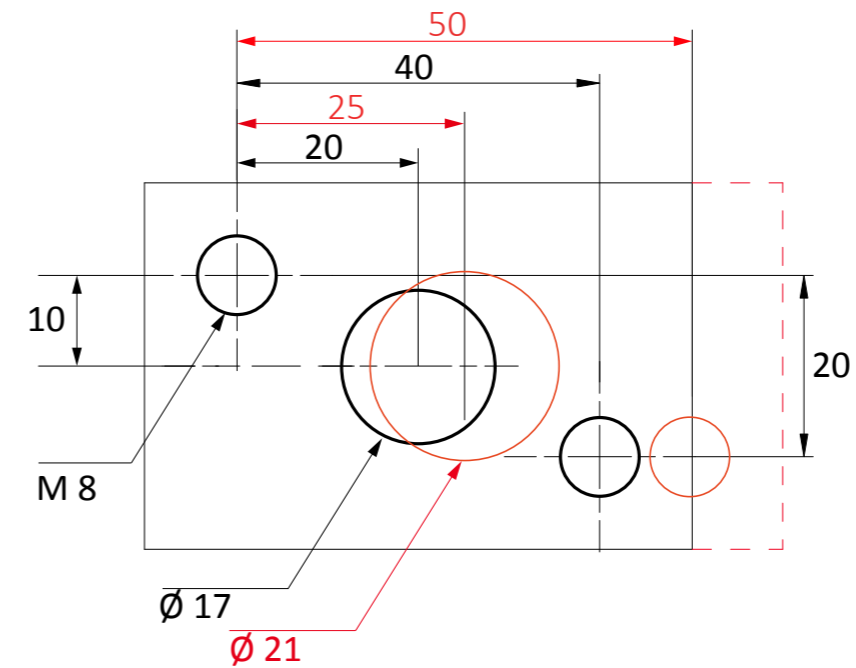

Dimensions in red with spindle diameter 20 mm
Dimensions in black with spindle diameter 16 mm

The KMS-2 can either be screwed directly into the spindle bridge or fixed to the spindle bridge with the optionally available Klemmfix.

Prerequisite:

Drill mounting holes and cut thread M8.

Working steps

1. Fix the Klemmfix with the enclosed 2 screws M8x35 (M8x40).
2. Pull the locking pin.
3. Press slide.
4. Insert threaded spindle up to pressure bridge. Push the slide back again.
⇒ Locking pin snaps in.
5. Set the cutting pressure using the star grip and read off the manometer.

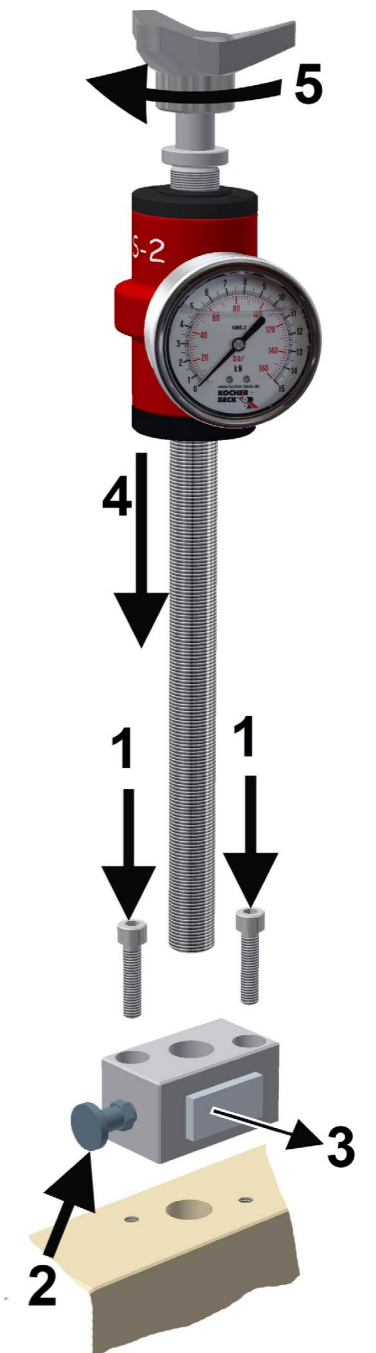

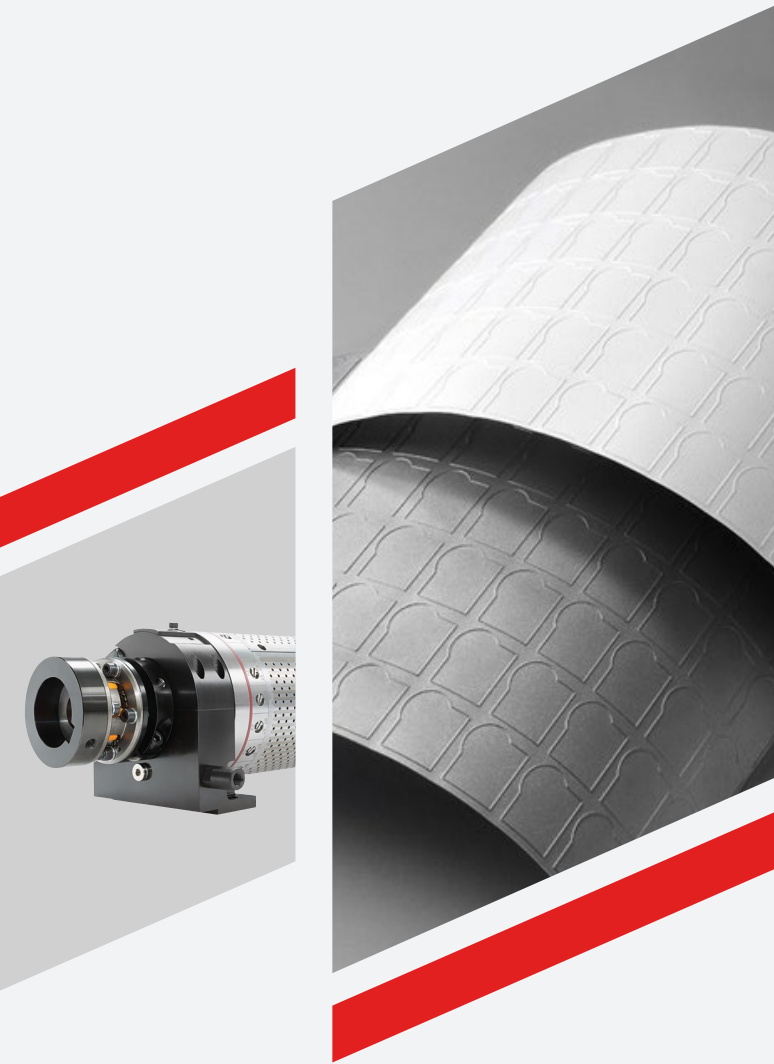

 **Contact Us**



Visit our Website